

3A, 23V, 340KHz Synchronous Rectified Step-Down Converter

MP2307

■ Features

- 3A Continuous Output Current, 4A Peak Output Current
- Wide 4.75V to 23V Operating Input Range
- Integrated 100mΩ Power MOSFET Switches
- Output Adjustable from 0.925V to 20V
- Up to 95% Efficiency
- Programmable Soft-Start
- Stable with Low ESR Ceramic Output Capacitors
- Fixed 340KHz Frequency
- Cycle-by-Cycle Over Current Protection
- Input Under Voltage Lockout

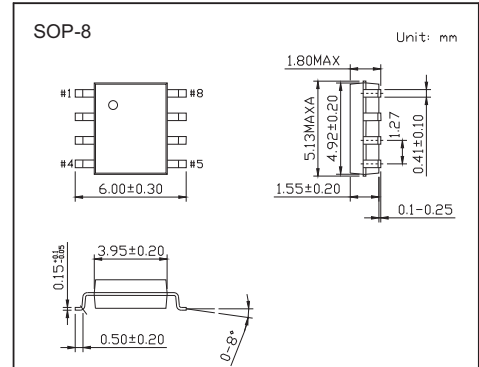

■ Functional Block Diagram

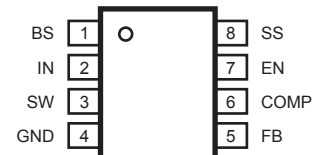
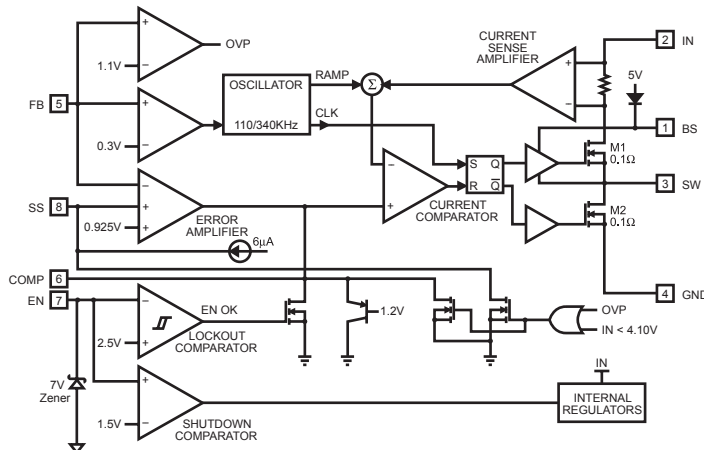

■ Absolute Maximum Ratings $T_a = 25^\circ\text{C}$

Parameter	Symbol	Rating	Unit
Input Voltage	V_{in}	-0.3 to 26	V
Switch Voltage	V_{sw}	-1 to $V_{in} + 0.3$	V
Boot Strap Voltage	V_{bs}	$V_{sw} - 0.3$ to $V_{sw} + 6$	V
All Other Pins		-0.3 to 6V	V
Power Dissipation	P_D	2.5	mW
Thermal Resistance	$R_{\theta JA}$	50	$^\circ\text{C}/\text{W}$
Junction Temperature	T_j	150	$^\circ\text{C}$
Storage Temperature	T_{stg}	-65 to 150	$^\circ\text{C}$
Lead Temperature	T_L	260	$^\circ\text{C}$

■ Recommended Operating Conditions

Input Voltage	V_{in}	4.75 to 23	V
Output Voltage	V_{out}	0.925 to 20	V
Operating Temperature	T_A	-40 to 85	$^\circ\text{C}$

MP2307

■ Electrical Characteristics (Ta = 25°C, VIN=12V, unless otherwise specified)

Parameter	Symbol	Condition	Min	Typ	Max	Units
Shutdown Supply Current		V _{EN} = 0V		0.3	3.0	μA
Supply Current		V _{EN} = 2.0V, V _{FB} = 1.0V		1.3	1.5	mA
Feedback Voltage	V _{FB}	4.75V ≤ V _{IN} ≤ 23V	0.900	0.925	0.950	V
Feedback Overvoltage Threshold				1.1		V
Error Amplifier Voltage Gain ⁽⁴⁾	A _{EA}			400		V/V
Error Amplifier Transconductance	G _{EA}	ΔI _C = ±10μA		820		μA/V
High-Side Switch On-Resistance ⁽⁴⁾	R _{DS(ON)1}			100		mΩ
Low-Side Switch On-Resistance ⁽⁴⁾	R _{DS(ON)2}			100		mΩ
High-Side Switch Leakage Current		V _{EN} = 0V, V _{SW} = 0V		0	10	μA
Upper Switch Current Limit		Minimum Duty Cycle	4.0	5.8		A
Lower Switch Current Limit		From Drain to Source		0.9		A
COMP to Current Sense Transconductance	G _{CS}			5.2		A/V
Oscillation Frequency	F _{osc1}		300	340	380	KHz
Short Circuit Oscillation Frequency	F _{osc2}	V _{FB} = 0V		110		KHz
Maximum Duty Cycle	D _{MAX}	V _{FB} = 1.0V		90		%
Minimum On Time ⁽⁴⁾	T _{ON}			220		ns
EN Shutdown Threshold Voltage		V _{EN} Rising	1.1	1.5	2.0	V
EN Shutdown Threshold Voltage Hysteresis				220		mV
EN Lockout Threshold Voltage			2.2	2.5	2.7	V
EN Lockout Hysteresis				210		mV
Input Under Voltage Lockout Threshold		V _{IN} Rising	3.80	4.05	4.40	V
Input Under Voltage Lockout Threshold Hysteresis				210		mV
Soft-Start Current		V _{SS} = 0V		6		μA
Soft-Start Period		C _{SS} = 0.1μF		15		ms
Thermal Shutdown ⁽¹⁾				160		°C

Note:

1) Guaranteed by design, not tested.

■ TypIacl Characteristics

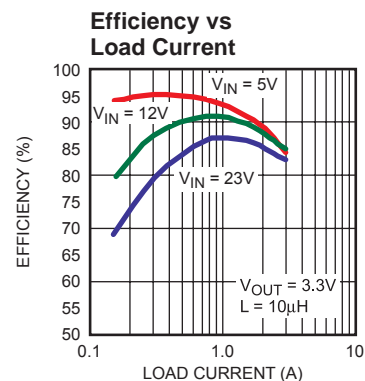
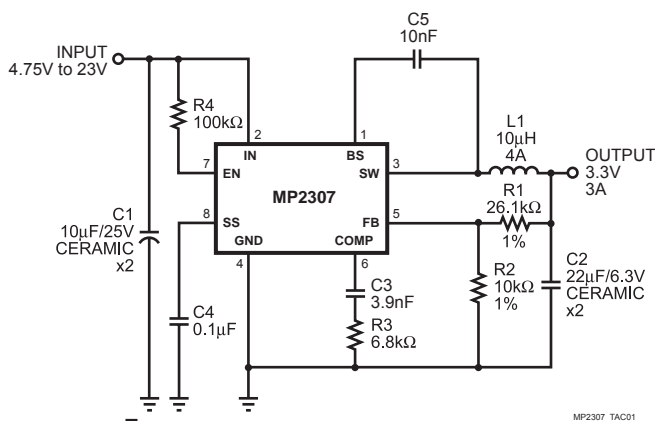

MP2307

■ Typical Characteristics

Steady State Test Waveforms

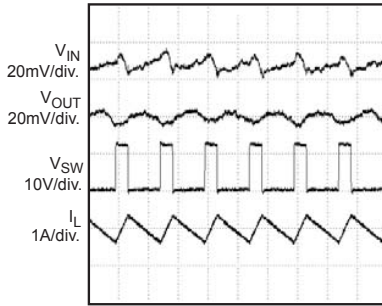
 $V_{IN} = 12V, V_{OUT} = 3.3V, I_{OUT} = 0A$ 

2μs/div.

MP2307-TPC01

Steady State Test Waveforms

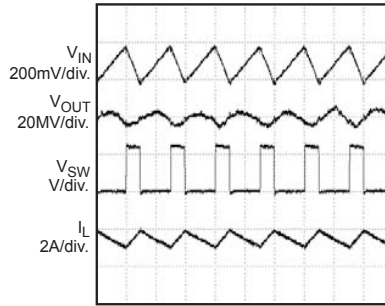
 $V_{IN} = 12V, V_{OUT} = 3.3V, I_{OUT} = 3A$ 

2μs/div.

MP2307-TPC02

Startup through Enable Waveforms

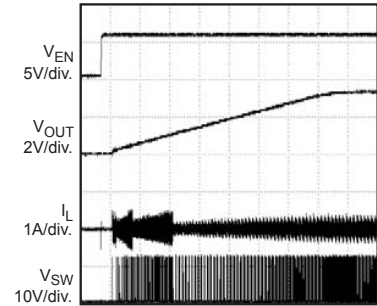
 $V_{IN} = 12V, V_{OUT} = 3.3V, \text{No Load}$ 

2ms/div.

MP2307-TPC03

Startup Through Enable Waveforms

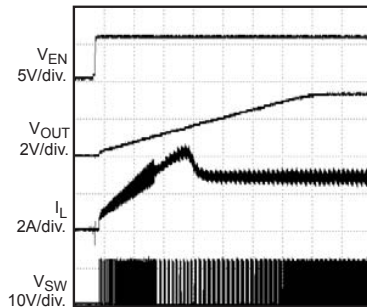
 $V_{IN} = 12V, V_{OUT} = 3.3V, I_{OUT} = 3A \text{ (Resistance Load)}$ 

2ms/div.

MP2307-TPC04

Shutdown Through Enable Waveforms

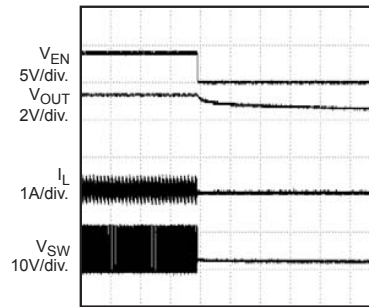
 $V_{IN} = 12V, V_{OUT} = 3.3V, \text{No Load}$ 

2ms/div.

MP2307-TPC05

Shutdown Through Enable Waveforms

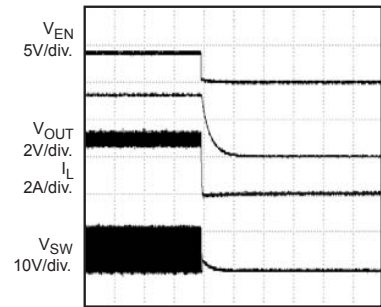
 $V_{IN} = 12V, V_{OUT} = 3.3V, I_{OUT} = 3A \text{ (Resistance Load)}$ 

200μs/div.

MP2307-TPC06

Load Transient Test Waveforms

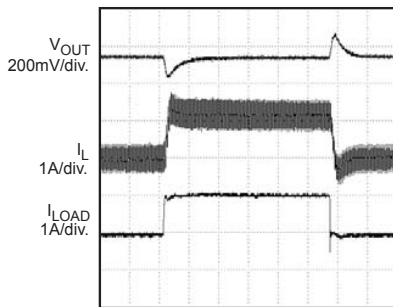
 $V_{IN} = 12V, V_{OUT} = 3.3V, I_{OUT} = 1A \text{ to } 2A \text{ step}$ 

50μs/div.

MP2307-TPC07

Short Circuit Test Waveforms

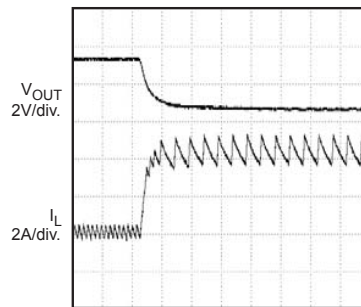
 $V_{IN} = 12V, V_{OUT} = 3.3V$ 

20μs/div.

MP2307-TPC08

Short Circuit Recovery Waveforms

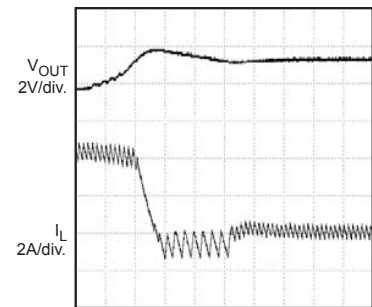
 $V_{IN} = 12V, V_{OUT} = 3.3V$ 

20μs/div.